

SPRY

User Manual

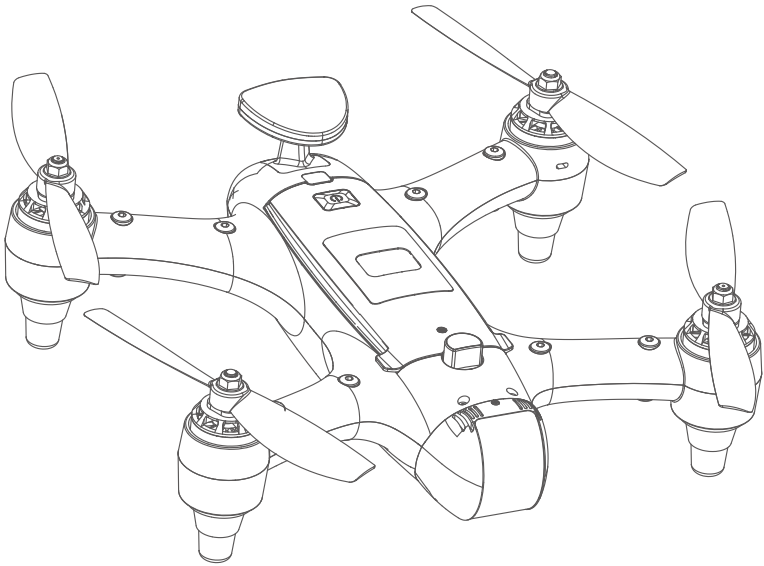

Thank you for purchasing the SwellPro Spry. Please read the entire contents of this manual thoroughly, to familiar with the product before using it.

Please note: This manual is correct at the time of release, and is subject to change without notice. Please check on our website: www.swellpro.com for the latest release.

Recommends

Before flying the drone, we strongly advise you to read through the User Manual, Disclaimer and Safety Operation Guide and then watch the tutorial videos.

Contents

Recommends	03
Product Overview	05
Brief Introduction	05
Highlighted Functions	05
Safety Operation Guideline	06
Disclaimer And Warning	07
Drone Illustrations	08
Remote Controller Illustrations	09
About the Drone	09
Flight Modes	10
One Key Return Home Function	11
Drone Indication Lights	12
Propellers	13
Micro SD Card Installation	14
Battery	14

Remote Controller	16
Charging Remote Controller Battery	16
Low Battery Alarm	16
Remote Controller Operation	16
Remote Controller Pairing	18
FPV Screen	19
Camera	20
Camera	20
Camera Settings and Use	20
Flight	22
Flight Introduce	22
Flight Environments	22
Flight Restriction	22
Pre-flight Inspections and Check	23
Accelerometer Calibration	23
Compass Calibration	24
Starting / Stopping the Motors	25
Basic Flight	26
APP Control	27
How to Use	27
Tap to Fly	28
Flight Path Settings	29
Appendix	29
Specifications	30
Warranty Information	31

Product Overview

This section introduces the various drone functions, how to assemble the drone, the various part names of the drone, and its remote controller.

Brief Introduction

Spry is the first-ever compact & portable waterproof sports drone.

Spry is the first-ever compact & portable waterproof sports drone. Fully waterproof fuselage and built-in HD camera, ensuring 4K/30fps video high speed shooting in all weathers. The competitive power system allows you to experience the high speed flight over water, enjoy the true freedom.

Highlighted Functions

1. The Spry fuselage and remote controller are waterproof and suitable for all-weather, all-terrain cruising.
2. The aerodynamic shape of the whole drone is designed base on the bionics to effectively minimize wind resistance and improve flight speed.
3. Spry's camera uses a Sony 1 / 2.3 inch CMOS sensor to match the lens, minimizing fisheye distortion and obtaining natural images. Use Spry to record stunning 4K video at 30 frames per second and get a maximum bit rate of 64mbps, or take high-definition 12MP photos.
4. Adjustable lens: Spry is with a steering gimbal. The camera has a 92.6° angle of view and the angle can be adjusted with the remote control.
5. Electronic image stabilization: electronic stabilize system combine with steering gimble, ensuring more smooth and high resolution footage.
6. Camera dome. The waterproof Spry 4K camera is sealed in an optical glass dome to protect the camera lens from damage. The specially designed dome has high transparency without distortion and can also avoid excessive glare.
7. Intelligent Follow Me: The Spry uses a built-in motion algorithm, ensuring more intelligent automatic Follow Me function and higher recognition accuracy. Preset a height and distance, whether you are walking or running, it can automatically follow you with the preset data.

8. Target orbit: by a simply switching, the Spry can change from Follow Me mode to target orbit mode, fly 360 degree around the target. When the target is moving, the Spry can do the Follow Me function while orbit the target.
9. Auto return: The normal aircraft will automatically record the return point when taking off. When it encounters communication interruption, insufficient power or receiving return flight command, it will automatically return to the take off point. The Spry can be dynamically adjusted during the flight based on the user's position and returned to the remote controller point. Even if you are on a moving boat, it will automatically return to your side.
10. APP smart control: One Key Take Off | Point to Fly | Orbit Fly | Auto Return | Flight Path Setting
11. Easy to use: Just press the button on the remote control, Spry can quickly respond to commands and complete the operation, no complicated settings, easy to use and control.

Safety Operation Guideline

- Please make sure you have a comprehensive understanding of the Spry and all the necessary measures required to implement a successful return home function, in the event of an emergency.
- Please be well prepared before each flight, to avoid any violent or excessive operations.
- Please follow the local laws; any flight in NO-FLY ZONEs is prohibited.
- Any illegal & improper use or operation of this product is highly prohibited.
- Any invasion & violation against another person' s right of privacy is not allowed. Before using this product, it remains the duty of the drone pilot to comply with the local laws regarding privacy protection.
- Any invasion or flying over another person' s property is not allowed.
- Any flight in or around the strong magnetic fields are highly prohibited, these influential factors include wireless electricity emission towers, High-voltage transmission lines, transformer substations, radar and other magnetic sources or metal objects.
- DO NOT fly the Spry under the influence of alcohol, drugs or any other physical or mental impediment.
- Please don't fly the drone with a malfunctioning radio controller.
- Please fly the drone away from crowds.

Disclaimer and Warning

SwellPro is exempt from the user's liabilities for damage(s) to a person/s or property, or injuries incurred directly or indirectly from the use of this product in the following conditions.

- Damage(s) or injuries incurred when the user/s are under the influence of alcohol, drugs or medication.
- Any malfunction caused by operators' failure to follow the guidance of the manual to assemble and set up, or operate the drone as described, and designed.
- Damage(s) or injuries that may occur due to failure to study the tutorial videos, and the user manual before flying the drone.
- Damage(s) or injuries caused to a person/s or property, due to failure in correctly calibrating the UAV as outlined in the manual, prior to flight.
- Damage(s) or injuries incurred as a result of the use or installation of any unauthorized third party accessories or counterfeit parts - which were not provided and approved of by SwellPro.
- Damage(s) or injuries as a result of flying the drone out of eyesight range, or more than 200m away from the controller.
- Damage(s) or injuries caused by flying the drone in areas of magnetic fields & radio interference.
- Damage(s) or injuries caused by flying in a NO-FLY ZONE which is regulated by the local laws & rules.
- Damage(s) or injuries including crashes, loss control or water ingress caused by abusing or modifying the original drone structure.
- Damage(s) or injuries caused by using broken & ageing components.
- Damage(s) or injuries caused by continuing to fly the drone even if the low battery alarm is activated.
- Damage(s) or injuries caused by failure to wash the components with fresh water after flying over or near the sea & corrosive waters.
- Damage(s) or injuries that have occurred when the drone has been subjected to the following conditions or situations: collision, fire, explosion, floods, tsunamis, ice, snow, avalanche, flooding, landslide, earthquake, etc.
- Damage(s) or injuries incurred by intentionally dropping or crashing the drone into the water from a high altitude, especially water ingress into the drone fuselage and Gimbal malfunction.

- Damage(s) or injuries incurred by intentionally dropping or crashing the drone to the ground from a high altitude, especially water leakage into the drone fuselage and Gimbal frame as a result of this collision.

- Other Damage(s) or injuries that are not SwellPro's liability.

Base on the laws and regulations, SwellPro reserves all the rights for final interpretation.

Drone Illustration

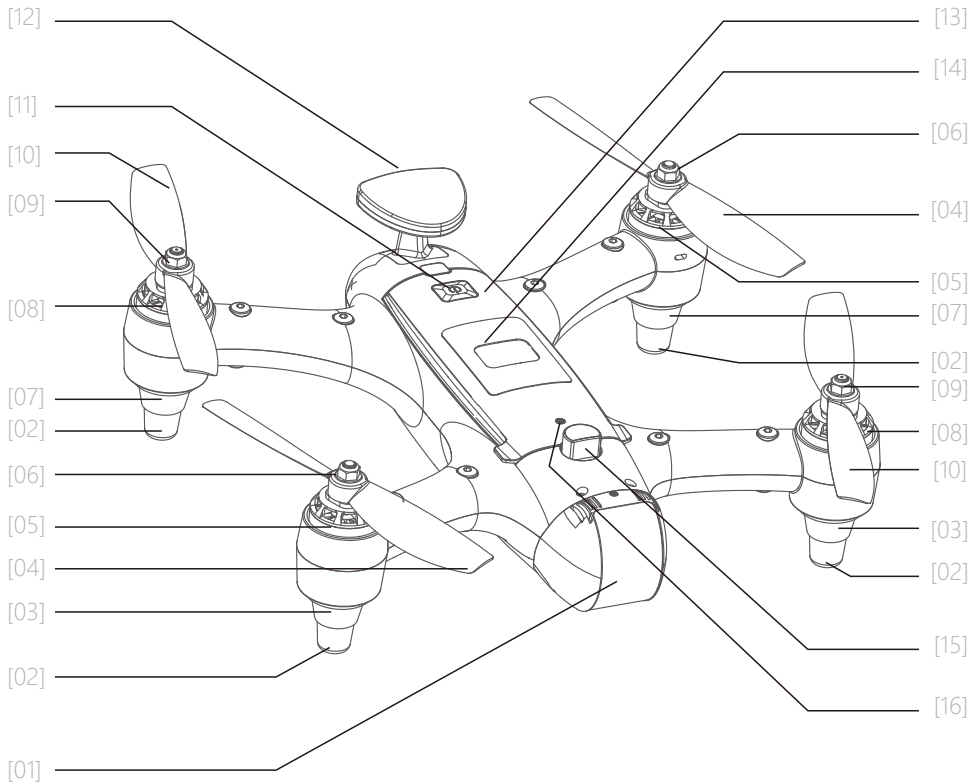

- | | | |
|-------------------------------|--------------------------------|--------------------------------|
| [01] Camera Lens Cover | [07] Working Indication Lights | [13] Battery Cover |
| [02] Rubber Feet | [08] CW Motor | [14] Ventilate Film |
| [03] System Indication Lights | [09] CW Propeller Screws | [15] Battery Cover Lock Buckle |
| [04] CCW Propellers | [10] CW Propellers | [16] Battery Cover Screw |
| [05] CCW Motor | [11] Power Button | |
| [06] CCW Propeller Screws | [12] GPS | |

Remote Controller Illustration

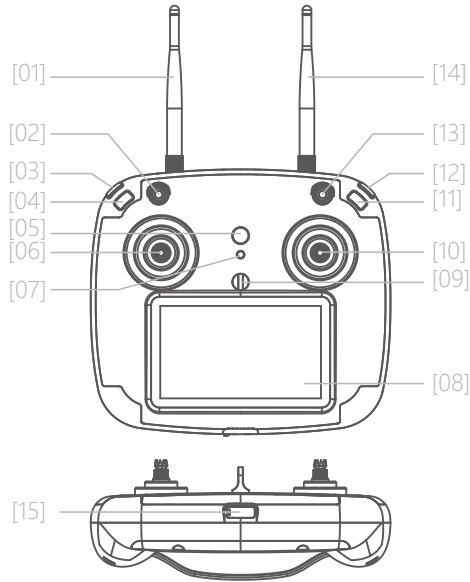

- | | | |
|--|--|---|
| [01] 2.4G Remote Antenna
For drone operation signal | [06] Left Joystick
Control the drone's ascend (up), descend (down) and/or to rotate the aircraft nose to the left or right. | [11] Camera Button
Used for taking Pictures and videos |
| [02] Return-Home Switch
Commands the drone to return automatically | [07] FPV Channel Button
Switch channel | [12] Camera up Button
Controls the camera up |
| [03] Camera down Button
Controls the camera down | [08] FPV Screen
Displays flight data and FPV video | [13] Flight Mode Switch
GPS / Cruise Flight / ATTI |
| [04] Follow Me Button
Controls the drone o follow the remote controller | [09] Hanger Ring
Attach belt | [14] 5.8G FPV Antenna
Transmits FPV video |
| [05] Power Button
Press to power on the drone | [10] Right Joystick
Controls the drone for forward, backward, left and right flight | [15] USB Port
For remote control firmware upgrade use and charging the remote controller |

⚠ Before powering on the controller, please be sure to put all the toggle switches on the controller (Return Home Switch and Flight Mode Switch) in the up position.

Note: The default remote control configuration is left hand as throttle. If you prefer to have right hand throttle, please consult your local dealer.

About the drone

This section introduces the drone and its functions.

Flight Modes

The Spry utilizes a brand new flight control system, incorporating 5 of the best flight modes.

GPS mode: This mode uses the GPS module to achieve accurate and stabilized hovering, intelligent flight, intelligent return and other intelligent flight mode functions. It enables a maximum flight speed of 10m/s, maximum ascend speed of 4m/s.

Circle mode: The drone moves above the target and begins to circle; will have a radius of 10 meters centered on the target, and the nose always facing the target. At this point, the right-hand joystick can control the aircraft, push backwards to increase the radius of the circle; push forward to reduce the radius of the circle and stop at the minimum radius of 10 meters; push the joystick to the left to speed up the circle fly speed; Push it to the right to lower the surround speed until you change the circle fly direction and increase the speed.

ATTI mode: This mode provides attitude stabilization and fixed height function. With a good GPS signal, intelligent return can be achieved. It enables a maximum flight speed of 18m/s, a maximum ascent speed of 4m/s.

Follow Me: The aircraft remote control has a GPS module, and the Follow Me mode is based on the relative position provided by the GPS module of the remote control and the aircraft. The maximum Follow Me speed is 10 m/s (36 KM/H).

Auto-Return: The aircraft has a One-key return function and return when the drone is lost control. When the remote control and GPS signal are good, the aircraft can be controlled to automatically return to the current remote control position.

⚠ In the GPS mode, it is recommended to take off after the GPS signal is up to or more than 8 stars, so as to ensure that the drone accurately records the return point.

When the Auto-Return function is activated, the drone can accurately return to the take-off point.

⚠ In ATTI mode, the drone's speed is faster. When flying in a calm environment, the pilot should allow a minimum of 30 meters for braking distance to ensure flight safety.

⚠ In the Follow Me mode, the remote joystick function is disabled. When press and hold the Follow Me button again, the indicator light will start flash red, indicating exit the Follow Me mode, and the joystick operation can be resumed. When the moving speed of the remote controller exceeds 10m/s, the maximum Follow Me speed of the drone is exceeded; at this time, the Spry stays in place and keeps hovering, and the Follow Me mode can be exited to resume the remote control. If the remote GPS positioning fails, the Follow Me function cannot be turned on.

Return Home



The aircraft has uncontrolled return and one-click return. Since the Spry remote control has a built-in GPS module, the remote control sends the remote controller coordinate information to the aircraft every second, so it has the function of returning to the remote control position. In order to return the flight more accurately and intelligently, the aircraft is set to stop receiving the remote controller coordinate information when it automatically returns to the horizontal distance of 30 meters from the remote controller.

When the remote control is turned off, or the aircraft loses the remote control signal beyond the remote control distance, the aircraft will auto-return to the last position of the remote control.

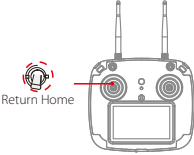
One Key Return Home Function

Remote Control Operation	Description
	<p>On: Flick the one-key return switch to the Return Home position for 2 seconds, the system will start the one-key return mode. At this point, the aircraft will auto-return to the remote controller. "RTH" is displayed in the upper right corner of the remote control screen.</p> <p>Off: Flick the one-key return switch to the Return Home position for 2 seconds to exit the one-key return mode.</p>

Return Process

Flare Maneuver	Description
	Vertical height > 20metres, the drone will maintain its altitude and return to its home point.
	Vertical height < 20metres, horizontal distance > 15metres, the drone will ascend up to 20metres, and then return to its home point.
	Vertical height < 20metres, horizontal distance > 15metres, the drone will ascend up to 20metres, and then return to its home point.

Auto-return

When the aircraft exceeds the remote control distance or the remote controller is turned off, the aircraft will execute the auto-return function, and its return process is consistent with the one-key return.

- ⚠ When the GPS signal of the aircraft is poor, the automatic return function cannot be activated, and the aircraft keeps hovering in place. Until the low power automatically landed.
- ⚠ When the remote control signal is restored, it is only necessary to switch the mode switch once in the attitude mode (ATTI) or in the GPS mode to take over control of the aircraft.

Drone Indication Lights

The fuselage of the drone includes a pair of nose LED indicator lights, and the drone status indicator lights on the rear arms. Their positions are shown below:

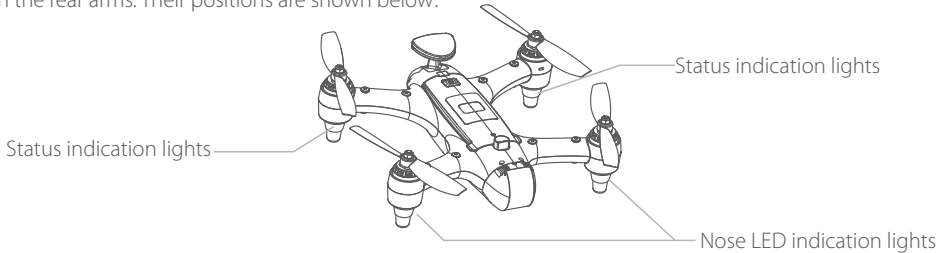

The nose LED indicator lights are used to indicate the direction of the nose of the drone, they will be solid green when the drone is powered on. The rear aircraft status indicator lights indicate the status of the current flight control system. Please refer to the following table for the different flash modes for the flight control system.

Drone status indicator

Aircraft initialization / horizontal calibration:

Alternating Red, Green slow flashing Aircraft initialization / horizontal calibration

Drone power on/off

Red Fast Flashing Remote control connected but still locked

Red ON Remote control connected and unlocked

Remote controller signal

Red Slow Flashing Remote controller signal lost

GPS Status

Green Slow Flashing Poor GPS signal

Green ON Good GPS signal

Compass Calibration

Green Fast Flashing Horizontal calibration

Green Slow Flashing Vertical calibration

Low Battery Warning

Red Fast Flashing Low battery warning

Propellers

Spry comes standard with a 6" 2-bladed propeller and is compatible with 5-inch 3-bladed propellers. The 2 blade speed is relatively slow, but the flight time is longer than the 3 blade; you can choose the blade according to preferences.

Installing and removing the propellers:

1. To facilitate the installation and removal of the propellers, use the attached tool to assist in the installation. (The large wrench holds the motor and the small wrench locks the nut that holds the propeller.)
2. The arrow indicates the mounting direction of the propellers.

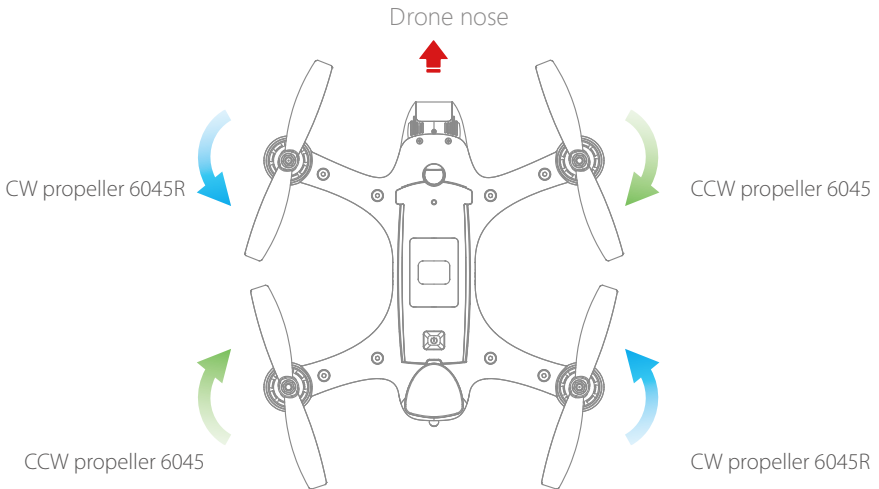

-
- ⚠ The blades are sharp, please be careful to avoid accidental cutting or scratches
 - ⚠ Before each flight, please check that the propellers are correctly installed and securely fastened
 - ⚠ If a propeller becomes damaged, or broken, please replace it, they can be purchased separately
 - ⚠ Please do not get too close to the rotating propellers and motors, to avoid cuts or injury
-

Micro SD Card Installation

a) Spry built-in 4K HD camera, the maximum recording frame is 240 frames, so it is recommended to use standard SD card of 10 times or more.

b) Remove the battery and you will see the Micro SD card slot, insert the SD card.

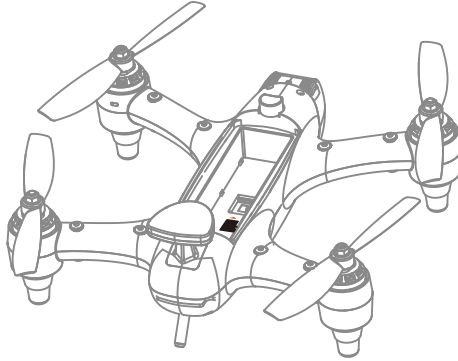

Battery

The Spry body uses a 2800 mAh high-voltage battery and is equipped with a corresponding high-voltage battery charger.

Charging the battery: After the power is turned on, all the LEDs of the charger will flash for 1 second. After the battery is connected to the balanced charging port, the battery can be charged. The four battery indicators on the charger represent 25%, 50%, 75%, and 100%. The 4 lights are ON indicating the battery is fully charged.

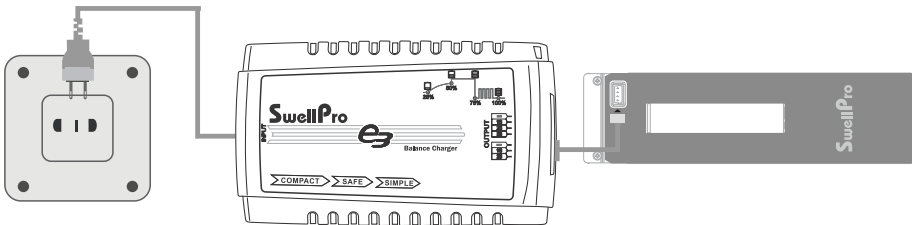

⚠ Note: When charging, the four indicators flash at the same time, indicating that the charger or battery is faulty. Please stop charging and check.

Battery Installation

- a) Grasp the raised end of the battery cover with the handle tool that comes with the strap and lift the battery cover up.
- b) Insert the battery vertically into the power outlet in the correct direction. Then cover the waterproof battery cover, press it tightly, and rotate the front knob to prevent the battery cover from opening automatically.

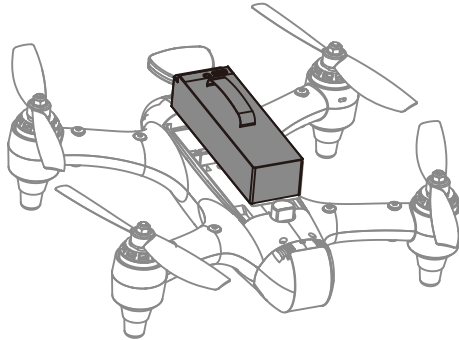

Low Battery Alarm

When the drone battery voltage is low, the LEDs on the rear arms will fast flash red, the remote controller will vibrate and the display shows "Aircraft Low Battery" and the aircraft enters the first level alarm (10.9V), please find a suitable place to land as soon as possible. When the aircraft voltage drops to 10.7V, the aircraft begins to slowly and automatically land. When the aircraft slowly and automatically landed, you can also choose a suitable landing site, but it should not be more than 1 minute, or fly too fast, otherwise the aircraft battery will be over-discharged, thus damaging the battery, or the aircraft will drop.

 Note: While operating the drone, when the voltage has dropped to the warning level and the warning appears, please prepare to return the drone to a safe landing place.

Low Temperature Precautions

1. In low temperature environments (-10C° to 5C°), the flight time will be reduced. Before use, please fully charge the battery, and keep it warm.
2. In low temperature environments, it is recommended to stop flying if and when the low battery alarm is on.
3. In low temperature environments, it is recommended to preheat the battery before fly the drone.

Remote Controller

This section introduces the remote controller functions, including the drone operation and the camera operation.

Charging Remote Controller Battery

The Spry remote has a built-in battery and charging circuit. Charge with a regular 5V USB charger. The minimum output current of the charger should be no less than 5V 2A, otherwise the charging time will be longer. The charging time is about 90 minutes. The remote control can work while charging.

⚠ Turn on the remote control when the remote control is charging, the remote control cannot enter the normal working state, which means the display screen can work normally, but the aircraft cannot be controlled.

Low Battery Alarm

The remote control has a built-in lithium battery and the working time is about 2 hours. When the remote control battery is low, the remote control will have a “DL...” sound. The battery power icon in the upper right corner of the screen will display red. At this time, the remote control will be about 10 minutes left until the automatic shutdown. Please retrieve the drone or charge the remote control battery.

Remote Controller Operation

The Spry remote control has two operating frequencies: 2.4 GHz and 5.8 GHz. 2.4GHz is the control channel of the remote control, and 5.8GHz is the image receiving channel of the display. The remote control has a built-in 4.3-inch FPV screen that displays real-time images and various status parameters of the aircraft.

Power ON and Power OFF

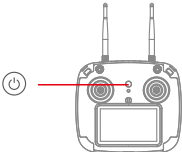
Remote Control Operation	Description
	Power on: Press the power button for 3 seconds, the remote controller will vibrate and screen will boot up. Power off: Press and hold the power button again for 3 seconds to turn off the remote control.

One Key Return Home

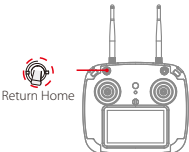
Remote Control Operation	Description
	On: Flick the return switch to the Return-Home position for 2 seconds, the aircraft enters the return state, and the FPV screen will display “RTH”. Exit: Flick the return switch to the Return-Home position for 2 seconds, and then flick any joysticks to exit the return flight.

Flight Modes

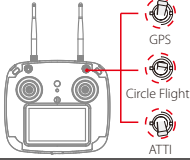
Remote Control Operation	Description
	<p>Description: GPS: GPS mode</p> <p>Smart Cruise: Smart Cruise Mode</p> <p>ATTI: ATTI mode</p>

⚠ Note: The aircraft can fly around a slowly moving object, and the speed of moving objects cannot exceed 4 m/s.

Follow Me Mode

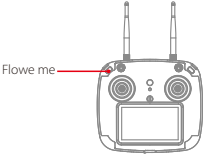
Remote Control Operation	Description
	<p>When the green indicator of the remote control is on, it indicates that the GPS positioning of the remote control is successful. At this time, press and hold the follow me button "F" for about 2 seconds, the green indicator light turns red and ON, indicating that the aircraft enters the Follow Me mode. Press and hold "F" for about 2 seconds again, the indicator light returns to steady green, indicating that the aircraft exits the Follow Me mode.</p>

- ⚠ In the Follow Me mode, the remote joystick function is disabled. Press the "F" button again, the indicator light stop flashing red, indicating exit the Follow Me mode, and the joystick operation can be resumed.
- ⚠ When the moving speed of the remote controller exceeds 10m/s, the maximum following speed of the drone is exceeded; at this time, the drone stays in place to keep hovering, and the Follow Me mode can be exited to resume the remote control.
- ⚠ If the remote GPS positioning fails, the Follow Me function cannot be turned on.

Gimbal Control

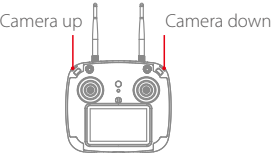
Remote Control Operation	Description
	<p>Camera up: Control camera to turn up</p> <p>Camera down: Control camera to turn down</p>

Camera Control

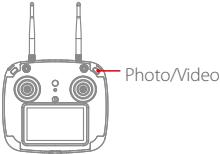
Remote Control Operation	Description
	<p>Photo/Video</p>

FPV Channel Adjust

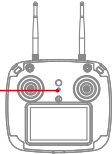
Remote Control Operation	Description
<p>channel adjustment button </p>	<p>Channel transmission adjustment: There are 8 channels in total; long press the channel adjustment button, the system will automatically search for channels.</p>

Drone Control

Left hand throttle- (American/ European configuration)

1. The left joystick controls the drone's ascend and descend (flick up and down) and the drone's heading (flick left and right).
2. The right joystick controls the forward/backward movement of the drone (flick up and down) and the left and right flight of the drone (flick left and right).

Left Stick

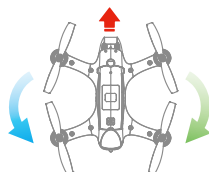
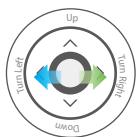
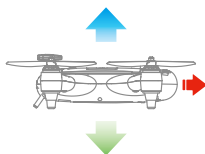

Right Stick

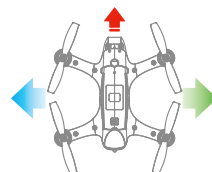
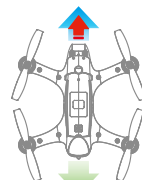

 Please contact us if you need to change to right hand throttle.

Remote Controller Pairing

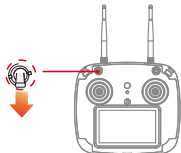
Remote Control Operation	Description
	<ol style="list-style-type: none"> 1. Flick to Return Home position and hold, press power button simultaneously to power on. 2. When the remote controller vibrating and sounding a "di" tone, the remote controller and the FPV channel will enter into pairing mode, and the remote controller indicator lights start Red-Green slow flash. 3. Press and hold the drone power button to turn it on. After pairing completed, the remote controller indicator lights will turn green. 4. Long press the image transmission channel switch, the FPV screen will display "RF SEARCHING" and automatically complete the switch of the image transmission channels.

⚠ The remote controller pairing and the image transmission channels must be adjusted simultaneously, to match the best channel to avoid mutual interference.

FPV Screen

Display Interface

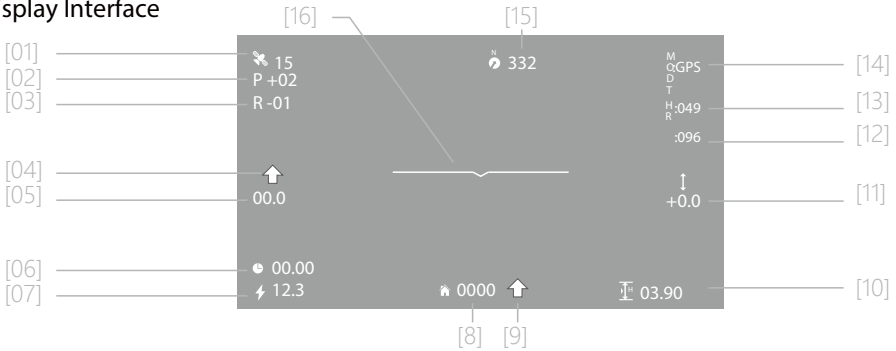

[01] GPS satellites	[07] Drone battery voltage	[13] Current throttle
[02] Angle of tilt	[08] Distance to the take off point	[14] Flight mode
[03] Angle of roll	[09] Drone's location to the return point	[15] Angle of the compass
[04] Flight direction	[10] Vertical height	[16] Flight attitude
[05] Flight speed	[11] Vertical flight speed	
[06] Unlock time	[12] Remote controller signal	

⚠ If [04] is consistent with [09], which means the drone is flying to the return point.

⚠ With the absence of obstacles, or without interference, the flight height can reach 80m or more, the video transmission range can reach 800m.

Camera

This section introduces parameters of the camera, and how to use it.

Camera

Spry's built-in advanced 4K HD camera, the largest pixel 14M, camera with WI-FI function, you can set camera parameters, mode, screen preview and download file through the APP.

Camera Settings and Use

1. APP installation: iOS systems for apple devices, please find the SwellCam 2 APP on the apple store and then install the APP. Android systems can download the APK installation on Android market or our website www.swellpro.com.
2. Camera WIFI connection: Power on the drone, switch on the camera WIFI, the red indicator will on and Red-Green fast flash. Open the WIFI on your phone, search for the name of SwellCam 2 mobile devices, and request to connect, enter the initial password 00000000, and connect.

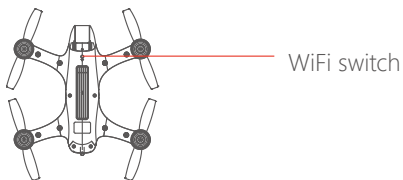

3. Using the APP: Open the camera APP into the camera preview interface. On the APP, you can set the parameters of the picture and video, APP can also control the camera for the taking of pictures or videos, and other related functions.

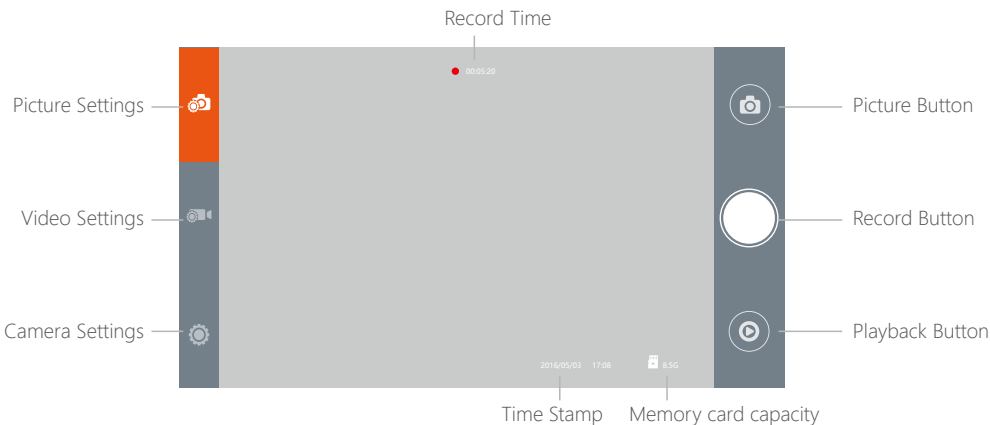

- ⚠ Please turn off the camera's WiFi switch before take off, in order not to interfere with the flight control or video transmission signals during flight.
- ⚠ When the camera is recording video, a sudden power cut will damage the video file.
Correct operation: turn the camera control switch to the preview position, stop the video and save it, and then disconnect the power of the drone.

Camera Settings

Picture Size	12M 16:9 12M 4:3
Burst Speed	OFF 3P/S 5P/S 10P/S
Timer	OFF 1s 3s 5s 10s
Selfie-Timer	OFF 5s 10s
Picture Mode	AUTO Manual control
Capture Speed	1/16000 1/8000 1/4000 1/2000 1/1000 1/500 1/250 1/120 1/30 1/24 1/20 1/15 1/8 1/4 1/2 1 2 4 8
ISO	AUTO 100 200 400 800 1600
Night Mode	ON OFF

Record Settings



Resolution	3840x2160 30P 2560x1440 60P 1920x1080 120P/60P/30P 1280x720 240P
Electronic Stabilization	ON OFF
Record Format	MP4 MOV
Video Format	PAL NTSC

- ⚠ When electronic stabilization is on, the distortion correction will be turned on at the same time.

Camera Settings

EV	+2.0 +1.7 +1.3 +1.0 +0.7 +0.3 0.0 -0.3 -0.7 -1.0 -1.3 -1.7 -2.0
White Balance	AUTO, cloudy, sunny, Incandescent lamp, Fluorescent lamp
Distortion Correction	ON OFF
Metering	Global metering, Center-weighted, spot
Format	Confirm Cancel
This camera	FW3.5
Default Setting	Confirm Cancel

Camera Indicator

	Green slow flash	Power on into preview mode
	Alternating Green-Red fast flash	WiFi ON
	Red Off	WiFi Off

Flight

This section describes flight considerations, flight restrictions, and drone cares.

Flight Introduce

After the installation, please continue reading the following sections to learn the flight procedures and precautions before flight. Taking professional training and guidance are recommended as well. Please be sure to find an appropriate flight environment.

Flight Environments

1. Please do not fly in terrible weather, such as excessive wind fog or other extreme weather.
2. Select an open place or water surface as an ideal flying site. Flying in between, or near a large number of steel buildings could adversely affect the compass or block the GPS signal, resulting in a poor positioning of the drone or even unable to locate.
3. When flying, try to keep the drone in your sight, keep away from obstacles and people.
4. Do not fly near high voltage lines, communication base stations, launch towers or other areas, which may interfere with the remote controller.
5. Flying at high altitudes, due to environmental factors, performance of the drone will decrease. Its batteries, power systems and flight performance will be adversely affected.

Flight Restrictions

According to the provisions of the International Civil Aviation Organization and national air traffic control airspace control, as well as the provisions of the UAV management, UAVs must be operated in prescribed airspaces. In consideration of flight safety, the safety fence is the default setting.

Limited height and distance

Safety fence: Has a maximum flight radius of 800meters and a maximum flight height of 200meters.

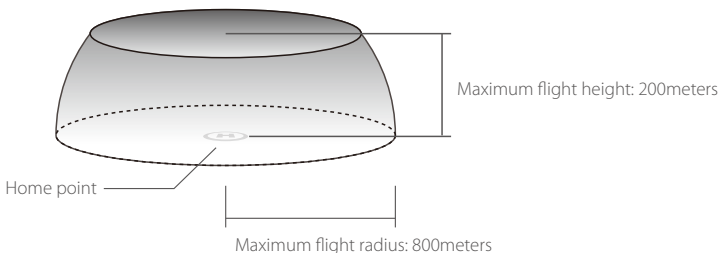

⚠ Flying in any flight modes would be limited by the safety fence.

Pre-Flight Inspection and Checks

1. Please ensure full batteries of both the drone and the remote controller.
2. Check if the propellers are correctly installed.
3. Make sure the micro SD card is properly inserted in the camera.
4. Check if the camera is working well.
5. Whether the motors can be started.
6. Please ensure the glass cover of the camera is clean.

Accelerometer Calibration

Calibration is necessary in any of the following situations:

1. First time to use the drone.
2. In the attitude stabilization mode (ATTI) the drone tilts a lot when it takes off.
3. When hovering in the attitude stabilization mode (ATTI), the drone does not drift slowly but obliquely when only the throttle stick is controlled.
4. A relatively large vibration occurred during transportation.

Accelerometer Calibration Steps:

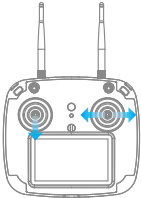
Remote Control Operation	Description
	<ol style="list-style-type: none">1. Place the drone on a horizontal surface, power on the remote controller and the drone, wait for the FPV interface exit the self-test and prompt the self-test is completed.2. Pull the left joystick vertically to the lowest position and then fast flick the right joystick left and right.3. When the fast blink indicator lights are ON, indicating the drone starts accelerometer calibration; when interface exit "AHRS INIT.....", the accelerometer calibration is finished, please power off the drone and start again.

Horizontal Calibration

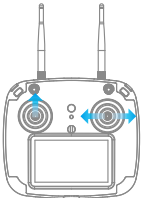
Remote Control Operation	Description
	<ol style="list-style-type: none">1. Place the drone on a horizontal surface, power on the remote controller and the drone, wait for the FPV interface exit the self-test and prompt the self-test is completed.2. Pull the left joystick vertically to the highest position and then fast flick the right joystick left and right.3. When the fast blink indicator lights are ON, indicating the drone starts horizontal calibration; when interface exit "AHRS INIT.....", the accelerometer calibration is finished, please power off the drone and start again.

 When doing horizontal calibration, please ensure that the aircraft is placed on a horizontal surface.

Compass Calibration

Calibration is necessary in the following situations:

1. Before flying the drone for the first time.
2. If 100KM or more away from the last compass calibration location.
3. The drone has been crashed/dropped by accident.
4. The drone keeps swaying / drifting during flight.
5. A relatively large vibration occurred during transportation.

Compass Calibration

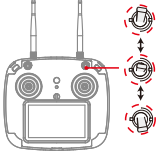
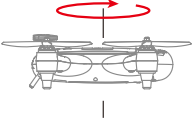
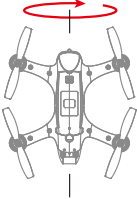
Remote Control Operation	Description
	<p>1. Place the drone on a horizontal surface, power on the remote controller and the drone. After the FPV interface exit the self-test, quickly switch the "Mode Switch", green lights fast flash (or the remote control screen displays HORIZONTAL CALIBRATION Rotate Drone Clockwise) indicating the calibration begins.</p>
	<p>2. Hold the drone horizontally, rotate counter clockwise until the green LED lights slow flash (or the remote control screen displays VERTICAL CALIBRATION Clockwise NOSE DOWN).</p>
	<p>3. Hold the drone nose vertically downward, rotate clockwise until the screen displays "INITIALIZING" indicating the calibration is finished. Place the drone on a horizontal surface for 30 seconds, power off the drone and start again.</p>

Starting / Stopping the Motors



Precautions before unlocking the motors:

- ⚠ Place the drone in an open area at least 3 meters away from you or others.
- ⚠ When the drone is powered on, the drone will do a self-check. When it's done, there will be a "DI" sound. Then keep the drone stationary.
- ⚠ If ATTI mode is selected, there is no need to wait, you can unlock the motors and proceed to takeoff and fly immediately. We recommend new pilots to unlock the motors in GPS mode. The motors can't be unlocked in cruise mode.
- ⚠ In the GPS mode, if the number of satellites is insufficient, the remote control will vibrate when unlocking the motors, and will display "the GPS signal is not good, cannot unlock the motors".

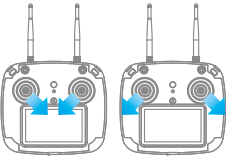
Unlocking the Motors

Remote Control Operation	Description
	<ol style="list-style-type: none">1. Pull both the left and right joysticks simultaneously towards the inner side of the lower side at an angle of 45°. Maintain this position for 3 seconds to unlock the motors.2. Pull both the left and right joysticks outward simultaneously of the lower side at an angle of 45°. Maintain this position for 3 seconds can unlock the motors as well.

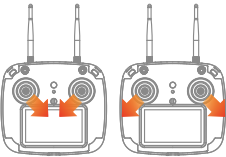
Stopping (locking) the Motors (operate cautiously)

Remote Control Operation	Description
	<ol style="list-style-type: none">1. Pull both the left and right joysticks simultaneously towards the inner side of the lower side at an angle of 45°. Maintain this position for 3 seconds to lock the motors.2. Pull both the left and right joysticks outward simultaneously of the lower side at an angle of 45°. Maintain this position for 3 seconds can lock the motors as well.
	<ol style="list-style-type: none">3. When the drone has landed smoothly, pull the throttle stick to the lowest position for 5 seconds to stop the motors.

- ⚠ In the GPS mode, if the number of satellites is insufficient, the remote control will vibrate when unlocking the motors, and will display "the GPS signal is not good, cannot unlock the motors".
- ⚠ In the cruise mode, the motors cannot be unlocked.
- ⚠ Unlock in ATTI mode will not be affected by GPS, it is recommended to unlock in GPS mode.

⚠ The motors can be stopped for any emergency. Stopping the motors while flying the drone may cause the drone crash, so it should only be operated in emergencies such as the drone may hit people, stopping the motors will minimize any potential damage.

Basic Flight Operation

1. Place the drone on a flat open surface or on the water, the pilot should face the drone tail.
2. Power on the remote controller and the drone.
3. Wait for the FPV screen to display the camera's live video, check if the OSD data is normal, and there should be more than 8 GPS satellites. Then the system enters into a safe flight status, you can unlock the motors and fly the drone.
4. Push the throttle joystick up slowly, allowing the drone to take off smoothly.
5. When you need to descend, slowly pull down the throttle joystick, allowing the drone to descend, and land on a flat surface or on the water smoothly.
6. After safely landing, keep the throttle down in its lowest position for at least 5 seconds until the motors stop.
7. Then power off the drone and the remote controller in turn.

⚠ Please watch the tutorial videos for more flight teaching.

APP Control

How to Use

The Spry remote has a built-in WI-FI module that can be used to control the aircraft to perform various intelligent automatic flight modes.

- 1.iOS systems for apple devices, please find the Spry APP on the apple store and then install the APP. Android systems can download the APK installation on Android market or our website www.swellpro.com.
- 2.After installation, open the WiFi of your phone, search the WiFi named Swell_xxxx and connect.
- 3.After connected successfully, the phone will display relevant data of the drone, such as voltage, coordinates, altitude, distance, GPS signal and other flight parameters.

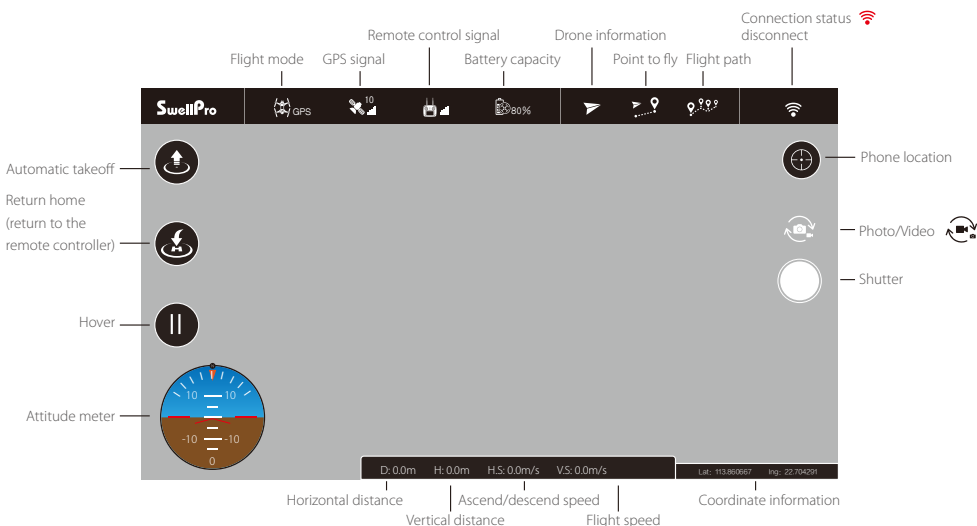

4. Once you have a minimum of 8 GPS satellites, you can unlock the drone and start flying with remote controller. You can also click the “takeoff” button on the APP and slide to unlock, the drone will ascend 3 meters and hover.

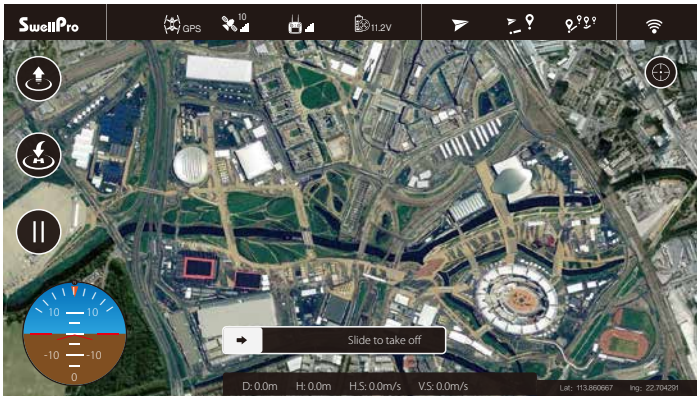
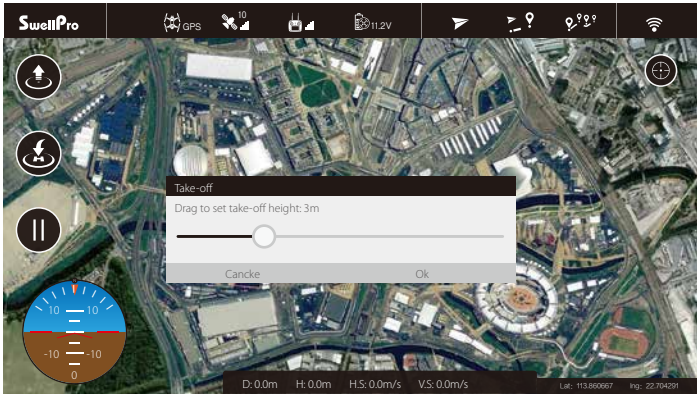

5. The APP allows to set hover, return home, flight path setting, follow me, tap to fly and etc.

6. **Tap-to-Fly:** Click the “Tap-to-Fly” button, and then click the target point on the map and click “Upload” button, the drone will start flying to the point and hover there. If you need to set the parameters manually, you can click the set flight point.

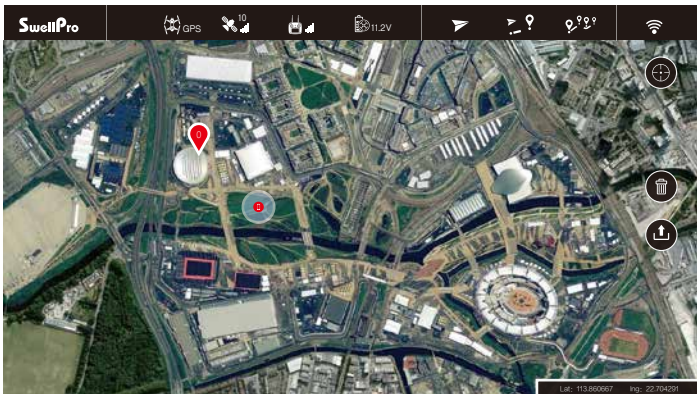

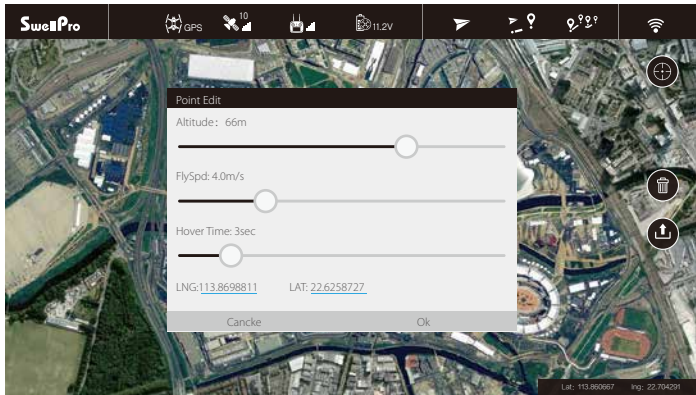

7. Flight Path Setting

a. Click the “Flight Path Setting” at the top of the screen and click map to set the flight path (double click the flight point to delete it, click the “Delete” button to delete all flight paths). Click the set flight point again to edit.

b. After completing the setup, click the “Upload” button and the drone will fly according to the flight path.

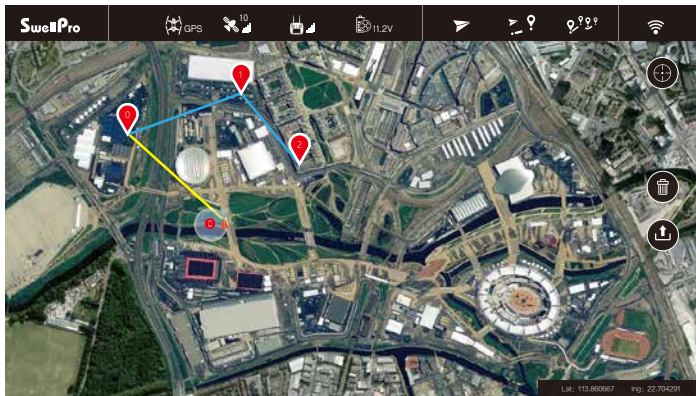

⚠ The APP control requires a good wireless communication environment. If the drone does not execute the operation command, it might be interfered, please try again.

⚠ If the drone continually fails to respond to your APP commands, please operate the drone with the remote controller: quickly switch mode switch once, it is suggested to use the GPS mode to take over control.

Appendix

Specifications

Drone

Waterproof Level	Surface Buoyant
Axis Diameter	270mm
Size (Length x width x height)	233.5 x 249 x 90mm
Weight	538g (Battery excluded)
Brushless Motors	2206 1400KV
Brushless ESC	30A
Propellers	#6045
Battery	3S 2800mAh LiHV battery
Battery weight	220g
Charging Time	About 70mins
Image Transmission Channels	5.8G 8CH
Image Transmission Range	500
Transmission power	200mW
Flight Time	15-17mins
Max Flight Range	800m
Max Flight Altitude	200m
Max Flight Speed	18m/s
Max Ascend Speed	4m/s
Max Follow Me Speed	10m/s
Positioning	GPS/GLONSS
APP Control	Automatic takeoff, automatic hover, automatic return home, point to fly, circling flight, flight path setting, camera control
Hovering Accuracy	±0.5m
Wind Resistance	>10m/s
Working temperature	-10 C -40 C

Remote Controller

Surface Buoyant	Surface Buoyant
Weight	480g (Battery excluded)
Frequency	2405-2475HMZ
Control Range	800m
Receiving sensitivity	(1%PER)-105dbm
Working Current	120 mA
Battery Capacity	2S 2000mAh LiPo
Charging Time	About 70mins

FPV Monitor

Frequency band 5645-5965HMZ

Image transmission channel 8

Screen Size 4.3inches

Resolution 800X480Pixels

Brightness 600 cd/m

Camera

Image Sensor 1/ 2.3 "CMOS, 1200M

Lens F4.53mm f / 2.65

Angle 92.6°

ISO Range 100-1600

Picture Resolution 12MP (16: 9)

Video Resolution 3840 * 2160 30P · 2560 * 1440 60P ·

1920 * 1080 30P / 60P / 120P · 1280 * 720 240P

Max Video Bit Rate 64mbps

Picture Format JPEG

Video Format MOV MP4

Storage Class 10 or UHS-1 and above specifications Micro SD card with max 64GB

Warranty Information

Please visit the Swellpro website to find out the latest information on:

Swellpro' s After-sales service policy:

Swellpro' s Maintenance service policy:

Note: When you receive the drone, please find the Buyer Registration on our official support page (<https://www.swellpro.com/service.html>) to register and activate the warranty (This is very important; it will ensure your drone is covered by the after-sales terms in the warranty period).



User Manual
V1.0 2018.10